

# AMERICAN AVK HIGH PRESSURE, 200 PSI WET BARREL HYDRANT

Meets or exceeds AWWA C503 (latest)

**242X/7X/9X  
WET DUCTILE**

**Use:**

For water and neutral liquids to maximum 160°F.

**Tests:**

Hydraulic test to AWWA C503:  
Shell Test: 400 PSI

**Options:**

Break Flange  
Hydrant Check Valve (FlowGuard II ® )  
Storz Nozzles, 2½" through 5"

**Approvals:**  
UL Listed,  
FM Approved



**Standard Materials:**

Nozzle Section	Ductile iron ASTM A536
Caps, Dummy Nuts	Cast iron ASTM A126 class B
Stems, Nozzles, Stem Nuts Thrust Nuts,	Bronze
Valve Discs	Bronze encapsulated with Nitrile Rubber
O-rings,	NBR
Cap Gaskets	Neoprene rubber
Nozzle Retainer Screws Thrust Collars	Stainless Steel
Cap Chains	Zinc Plated Steel
Coating	Electrostatically applied fusion-bonded epoxy-resin

Note: Nozzles, Stem Nuts and Stem Seals field replaceable

Pumper Nozzles interchangeable from 4" to 4½"

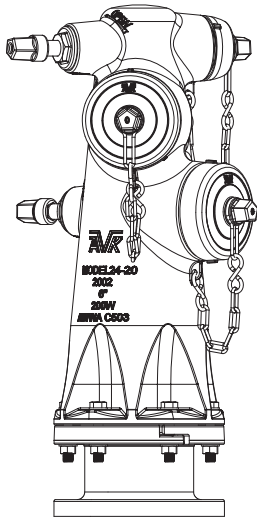

Series 2420  
2 Pumper, 1 Hose Outlet \*

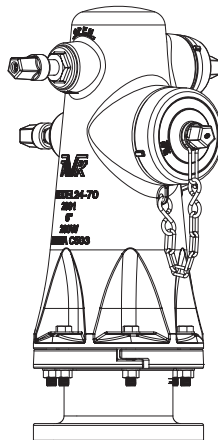

Series 2470  
1 Pumper, 1 Hose Outlet \*

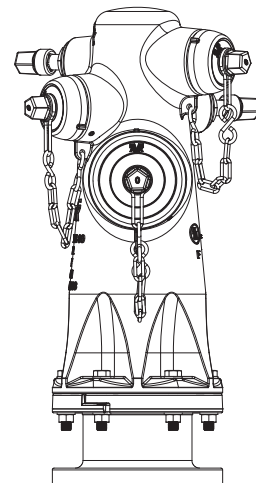

Series 2490  
1 Pumper, 2 Hose Outlets \*

\* Shown with optional Breakable Flange Assemblies  
Note: All configurations supplied with 6 - 3/4" holes at 9 3/8" pitch diameter.  
Breakable Flange Assemblies with 6" ANSI Standard 8 hole configuration are available as an option.



American AVK Company  
an ISO 9001-2000 registered company

DS S242X/7X/9X WET DUCTILE  
Subject to change without notice. (rev. 01/09)

# AMERICAN AVK HIGH PRESSURE, 200 PSI WET BARREL HYDRANT

Meets or exceeds AWWA C503 (latest)

**242X/7X/9X  
WET DUCTILE**

## Component List:

- |  |                               |                                |
|--|-------------------------------|--------------------------------|
| 19. Hose Nozzle Cap                    | 112. Dummy Nut                | 127. Wet Barrel Flange Section |
| 22. Hose Nozzle O-Ring                 | 113. Dummy Nut Retaining Bolt | 133. 2.5" Valve Disc           |
| 23. Nozzle Retaining Screw (not shown) | 114. Stem Nut Retaining Screw | 134. 2.5" Valve Stem           |
| 24. Chain Set                          | 115. Hose Nozzle Cap Gasket   | 135. 2.5" Thrust Nut           |
| 25. Pumper Nozzle O-Ring               | 116. Hose Nozzle              | 136. 2.5" Thrust Collar        |
| 28. Pumper Cap                         | 120. Pumper Cap Gasket        | 137. 4.5" Valve Disc           |
| 31. Nozzle Section Washer              | 122. Nozzle Section Bolt      | 138. 4.5" Valve Stem           |
| 101. Nozzle Section                    | 123. Wet Barrel Flange O-Ring | 139. 4.5" Thrust Nut           |
| 109. Outer Stem Nut O-ring             | 124. Break Ring               | 140. 4.5" Thrust Collar        |
| 110. Stem Nut                          | 125. Nozzle Section Nut       | 141. 4.5" Thrust Nut O-ring    |
| 111. Inner Stem Nut O-Ring             | 126. Pumper Nozzle            | 142. 2.5" Thrust Nut O-ring    |

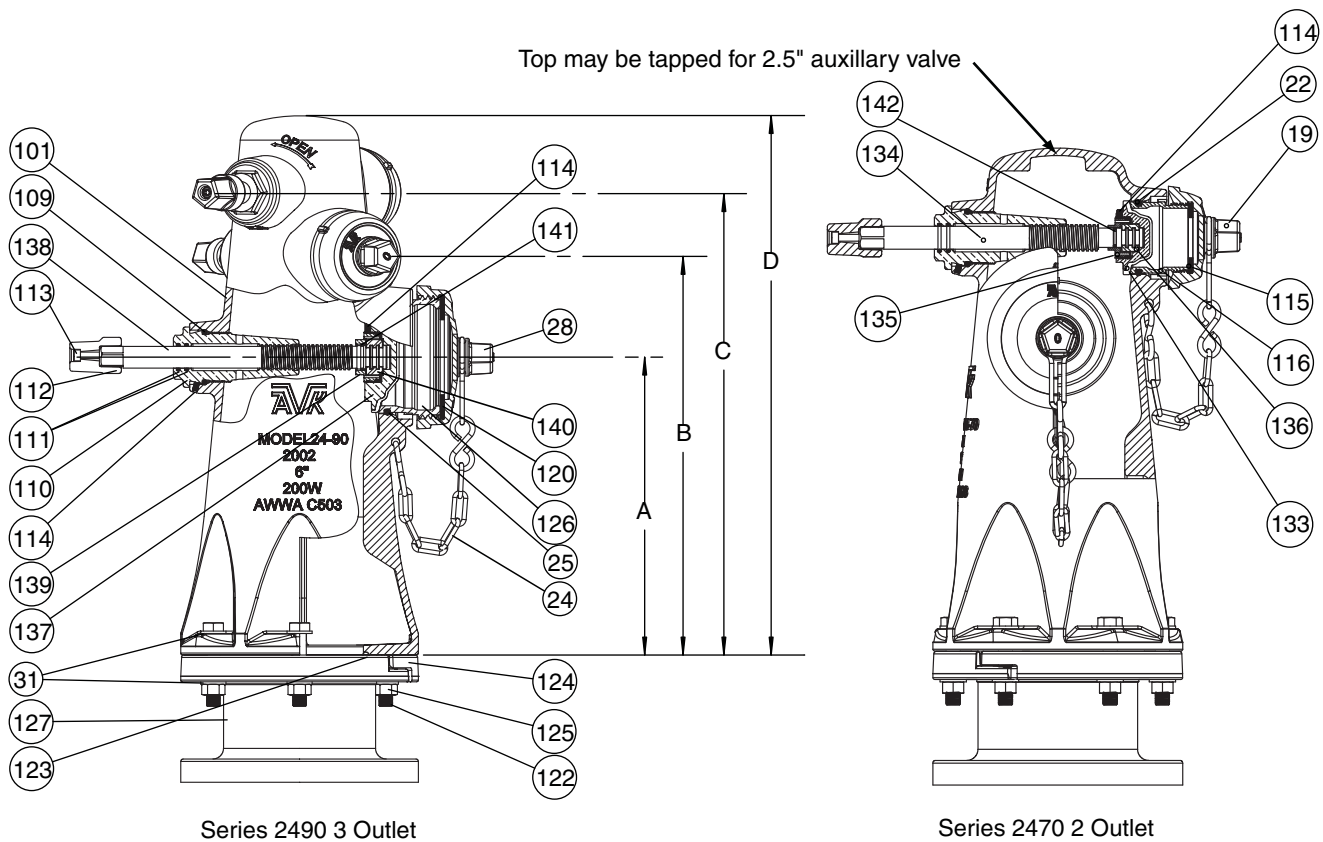

Ref No.	Outlets	A	B	C	D	Weights (lbs)
24-150-7X	1x2.5"	14"	18.50"	-	22.50"	101
24-150-7X	1x4"/4.5"	14"	18.50"	-	22.50"	101
24-150-2X	1x2.5"	14"	20.00"	24.75"	27.50"	126
24-150-2X	2x4"/4.5"	14"	20.00"	24.75"	27.50"	126
24-150-9X	2x2.5"	14"	18.75"	21.75"	25.00"	126
24-150-9X	1x4"/4.5"	14"	18.75"	21.75"	25.00"	126

With optional factory assembled breakable unit, add 42 lbs. to shipping weight.

