

AMERICAN AVK RESILIENT SEATED GATE VALVE
250 PSI, Tested to AWWA C509 (NRS)
Mechanical Joint End, Cut-In - Valve Sizes 4" - 12"

25/AX
MJxMJ/CUT-IN

Use:

For water and neutral liquids to maximum 160°F.

Tests:

Hydraulic test to AWWA C509:

Shell Test: 500 PSI

Seat Test: 250 PSI

Operating Torque Test

Optional Materials:

Stem	Option a): Low zinc bronze ASTM B763
Anti Friction Washers	Polyamide
Bonnet Bolts	Option a): ASTM A164 zinc coated steel sealed with hot melt Option b): Stainless Steel - 316 sealed with hot melt
Gland Bolts	Option a): ASTM A164 zinc coated steel Hexagon bolt Option b): Stainless Steel - 316 Hexagon bolt

Note: Cut-in sleeves provided by other vendors.

Standard Materials:

Body, Bonnet, Gland Flange Coating	Cast iron ASTM A126 class B Ductile iron ASTM A536 Electrostatically applied fusion- bonded epoxy-resin Meets or exceeds AWWA C550
Wrench Nut	Ductile iron ASTM A536 - painted black for open left, red for open right.
Stem	Standard: Stainless Steel, ASTM A582
Wedge	Ductile iron ASTM A536 encapsulated with EPDM-rubber compound
Wedge Nut	Bronze
Bonnet Bolts	Stainless Steel - 304 sealed with hot melt
Gland Bolts Hexagon bolt	Stainless Steel - 304
Bonnet Gasket Wiper Ring, O-Ring Stem Seals, O-Ring Gland Seal	ASTM D2000 Buna "N" nitrile rubber

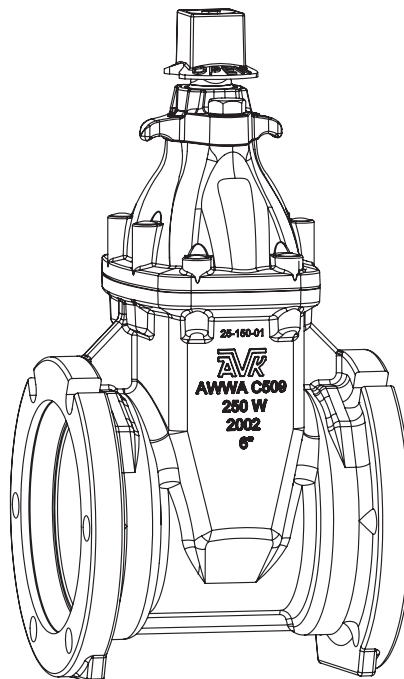

American AVK Company
an ISO 9001-2000 registered company

DS S25AX MJMJ/CUT-IN
Subject to change without notice. (rev. 06/06)

AMERICAN AVK RESILIENT SEATED GATE VALVE
250 PSI, Tested to AWWA C509 (NRS)
Mechanical Joint End, Cut-In - Valve Sizes 4" - 12"

25/AX
MJxMJ/CUT-IN

Component List:

- | | | |
|--------------------|------------------------------|-----------------------------|
| 217. Bonnet | 227. Gland Flange Bolt | 232. Lower Stem Seal O-Ring |
| 218. Bonnet Gasket | 228. Gland Flange | 233. NRS Stem |
| 219. Body | 229. Gland O-Ring | 234. Thrust Collar |
| 225. Wrench Nut | 230. Upper Stem Seal O-Rings | 237. Wedge |
| 226. Wiper Ring | 231. Stem Seal Bushing | |

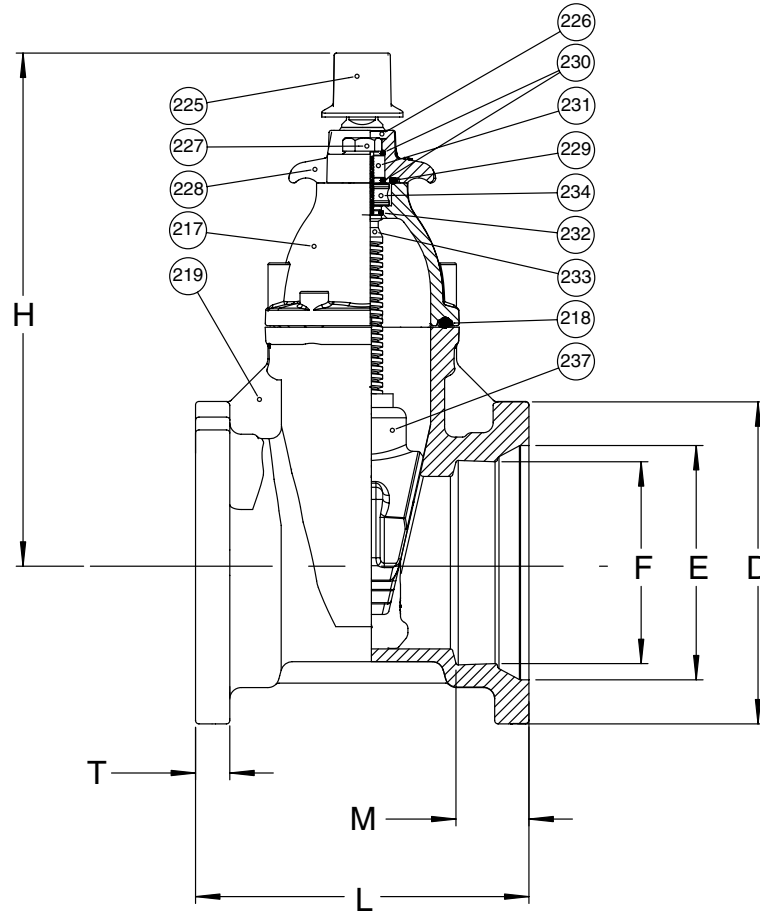

Ref No.	Size	D	E	F	H	L	M	T	Turns to Open	Wt. Lbs.
25-101-AX	4"	9.12"	6.02"	5.17"	13.50"	10.00"	2.53"	1.00"	14	62
25-151-AX	6"	11.12"	8.12"	7.27"	17.50"	11.50"	2.53"	1.18"	21	121
25-201-AX	8"	13.37"	10.27"	9.47"	21.50"	11.50"	2.55"	1.24"	26	173
25-251-AX	10"	15.69"	12.34"	11.60"	24.75"	13.00"	2.55"	1.14"	32	240
25-301-AX	12"	17.88"	14.44"	13.54"	27.63"	14.00"	2.55"	1.22"	38	398

