

**AMERICAN AVK HIGH PRESSURE, 250 PSI, MODERN,  
SINGLE PUMPER, DRY BARREL HYDRANT**

**2712  
MODERN SINGLE PUMPER**

Meets or exceeds AWWA C502 (latest) - Working Pressure - 250 PSI

Inlet Bases: Flanged in accordance with ANSI B16.1 Class 125,

Mechanical and Push-On Joint in accordance with ANSI/AWWA C111/A21.11

**Use:**

For water and neutral liquids to maximum 160°F.

**Tests:**

Hydraulic test to AWWA C502:

Seat Test: 500 PSI

**Components:**

Nozzle Section, Bonnet, Barrels, Standpipe Flanges,  
Breakable Flange, Main Valve Flange, Base, Upper Barrel

Caps, Weathershield

Nozzles, Valve Seat Ring, Drain Ring  
Operating Nut, Thrust Nut

Brass Fittings, Brass Plugs

Main Valve

Stem Rod Couplings, Lock Rings, Nozzle Retaining  
Screw, Lock Plate, Lock Plate Screw, Spider Bolt, Stop Pins,  
Coupler Pins, Main Valve Retaining Pin, Spring Pins,

Coating

Stop Nut, Chain Set, Hardware

Barrel Gasket, Cap Gasket, O-rings

Lubrication Hole Seal

Anti-Friction Washer

Base Elbow / Inlet Configuration

6" MJ

4" MJ

8" MJ

**Standard:**

Ductile Iron ASTM A536

Cast Iron ASTM A126 Class "B"

Bronze

Brass

Ductile iron core, fully encapsulated with EPDM rubber.

Stainless Steel

Above ground-Fusion bonded epoxy inside and out. Below  
ground - Bitumen/Fusion bonded epoxy. Epoxy meets or  
exceeds AWWA C550 (latest)

Zinc Plated Steel

NBR - ( Barrel Gasket with 304 stainless insert )

Oil Resistant Rubber

Polyamide

6" Flanged

4" Flanged

Straight Flanged 6"

6" Push-on

4" PE

6" PE

**Optional Materials:**

Hardware

Upper Stem Rod

Lower Stem Rod

Opening Direction

Zinc Plated

304 Stainless

304 Stainless

Open Left

304 Stainless

Epoxy Coated Steel

Epoxy Coated Steel

Open Right

316 Stainless



American AVK Company  
an ISO 9001-2000 registered company



Series 2712  
1 Pumper

DS S2712 MODERN SINGLE PUMPER  
Subject to change without notice. (rev. 12/07)

# AMERICAN AVK HIGH PRESSURE, 250 PSI, MODERN, SINGLE PUMPER, DRY BARREL HYDRANT

2712  
MODERN SINGLE PUMPER

Meets or exceeds AWWA C502 (latest) - Working Pressure - 250 PSI

Inlet Bases: Flanged in accordance with ANSI B16.1 Class 125,

Mechanical and Push-On Joint in accordance with ANSI/AWWA C111/A21.11

## Component List:

- |                            |                            |                                  |                               |
|----------------------------|----------------------------|----------------------------------|-------------------------------|
| 1. Weathershield Bolt      | 23. Nozzle Retaining Screw | 37. Breakable Stem Rod           | 57. Main Valve Flange         |
| 2. Weathershield           | 24. Chain Set              | Coupling                         | -Detail B                     |
| 3. Lock Plate Screw        | 25. Pumper Nozzle O-ring   | 38. Spring Pin                   | 58. Stop Pin -Detail B        |
| 4. Lock Plate              | 26. Pumper Nozzle          | 39. Spider                       | 60. Main Valve Retaining Pin  |
| 5. Inner Thrust Nut O-ring | 27. Pumper Nozzle Gasket   | 40. Spider Bolt                  | -Detail B                     |
| 6. Thrust Nut              | 28. Pumper Nozzle Cap      | 41. Lower Stem Rod               | 61. Main Valve Disc -Detail B |
| 7. Outer Thrust Nut O-ring | 29. Nozzle Section         | 46. Standpipe Flange -Detail B   | 62. Base Gasket -Detail B     |
| 8. Anti-Friction Washer    | 30. Nozzle Section Bolt    | 49. Lower Barrel                 | 64. Stud Bolt -Detail B       |
| 9. Lubrication Hole Seal   | 31. Nozzle Section Washer  | 50. Lower Barrel O-ring Detail B | 67. Base                      |
| 10. Operating Nut          | 32. Lock Ring              | 51. Valve Seat O-ring -Detail B  | 71. Modern Nozzle Section     |
| 11. Stop Nut               | 33. Breakable Flange       | 53. Valve Seat O-ring -Detail B  | Bolt                          |
| 15. Stem Seal O-rings      | 34. Nozzle Section Nut     | 54. Drain Ring -Detail B         | 75. Zerk Fitting (not shown)  |
| 16. Upper Stem Rod         | 35. Upper Barrel           | 55. Brass Plug -Detail B         |                               |
| 17. Barrel Gasket          | 36. Coupler Pin            | 56. Brass Fitting -Detail B      |                               |

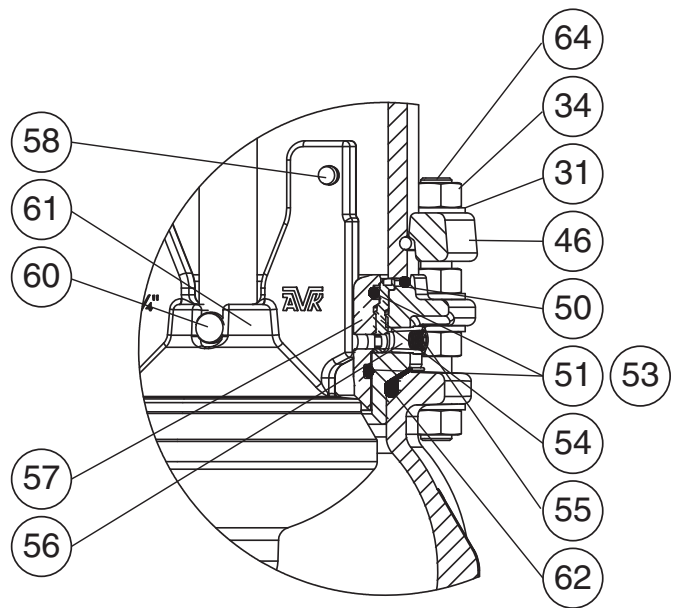
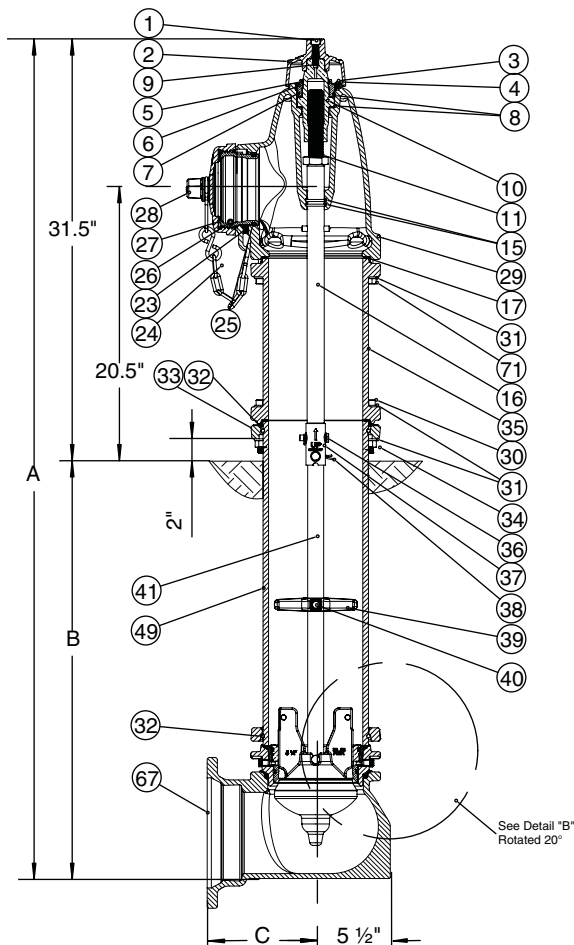

Detail "B"

Ref No.	Outlets	A	B*	C			
				Flanged	MJ	Push-on	PE
27-12 - 4"	2x2½", 1x4"/4½"	49.50" - 242.50"	18" - 216"	8.00"	8.00"	N/A	23.70"
27-12 - 6"	2x2½", 1x4"/4½"	49.50" - 242.50"	18" - 216"	8.00"	8.00"	9.00"	22.80"
27-12 - 8"	2x2½", 1x4"/4½"	49.50" - 242.50"	18" - 216"	N/A	9.38"	N/A	N/A

\* Buries greater than 216" available upon request.

