

**AMERICAN AVK SWING CHECK VALVE, 250 PSI**  
**Tested to AWWA C508 - Bronze Seated with Lever & Weight**  
**Flanged Ends Drilled to ANSI B16.1 Class 125 - Valve Sizes 3" - 12"**

**41/56-57X**  
**BRNZ/LW**

**Use:**  
 For potable water and sewage to maximum  
 160°F.

**Tests:**  
 Hydraulic test to AWWA C508:  
 Shell Test: 500 PSI  
 Seat Test: 250 PSI

**Optional Extras:**  
 Available with Lever right-hand or left-hand mounted.  
  
 Resilient seated disc assembly.  
  
 Dual Lever&Weight  
  
 Tapping boss, tapped and plugged.  
  
 Priming Device

<b>Standard Materials:</b>	
Body, Bonnet, Weight, Lever	Ductile iron, ASTM A536
Coating	Electrostatically applied fusion-bonded epoxy. Meets or exceeds AWWA C550
O-Rings, Bonnet Gasket	NBR
Shaft, Hinge, Bonnet Bolts, Washers, Keys	Stainless steel
Bushings Body & Disc Seal	Bronze
Bronze Seated Disc	EPDM rubber with a carbon steel core and bronze seat.

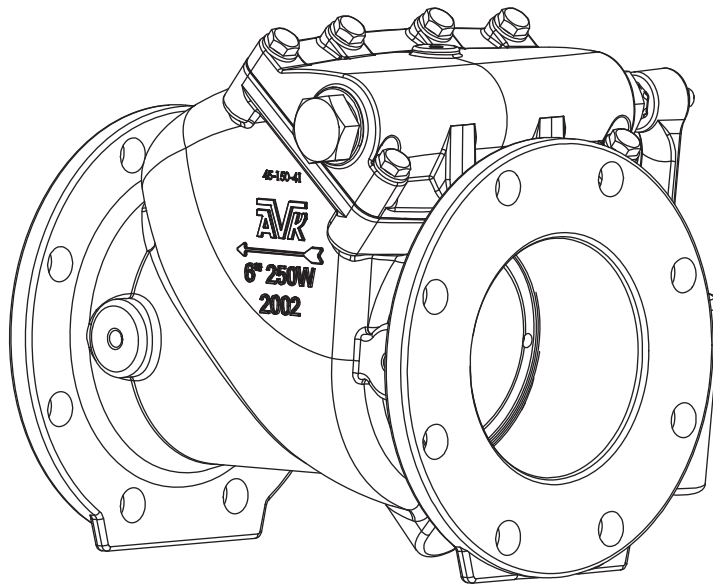

C508 clear waterway design. Laylength to ANSI B16.10



**AMERICAN AVK SWING CHECK VALVE, 250 PSI**  
**Tested to AWWA C508 - Bronze Seated with Lever & Weight**  
**Flanged Ends Drilled to ANSI B16.1 Class 125 - Valve Sizes 3" - 12"**

**41/56-57X**  
**BRNZ/LW**

**Components**

400. Body	406. Bonnet Bolt	412. Bonnet Gasket	418. Inner Bushing O-ring	423. Disc Lock Washer**
401. Disc Nut**	407. Bonnet	413. Disc	419. Weight	429. Bonnet O-ring*
402. Disc Washer	408. Shaft	414. Shaft Nut	420. Set Screw	430. Hinge Connector*
403. Disc Bushing	409. Key	415. Shaft Washer	421. Outer Bushing O-ring	431. Retaining Washers*
404. Hinge	410. Lock Washer	416. Lever	422. Closed Bushing	432. Shaft Spacers*
405. Bonnet Washer	411. Hinge Bolt	417. Open Bushing		

\* 10" and 12" Valves ( not shown )

\*\* As of March 1st, 2008 on 3" through 8" valves, the Disc Lock Washer (423), and Disc Nut (401), are replaced by a new self locking Disc Nut (401).

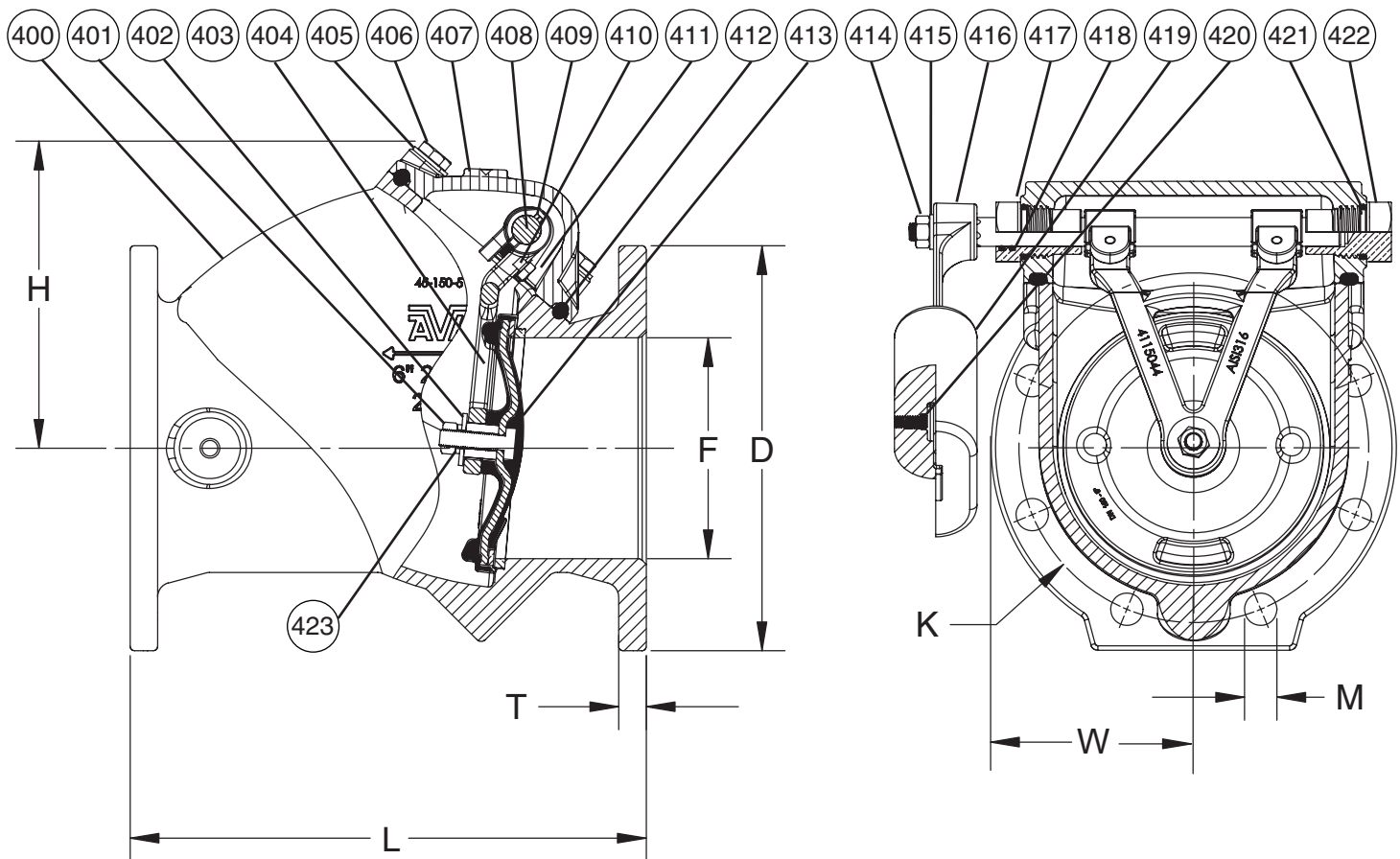

Ref No.	Size	D	F	H	K	L	M	T	W	Flange Holes	Weight (lbs.)
41-080-56-57X	3"	7.50"	3.00"	5.50"	6.00"	9.50"	0.75"	0.75"	3.76"	4	35
41-100-56-57X	4"	9.00"	4.00"	6.00"	7.50"	11.50"	0.75"	0.75"	4.50"	8	51
41-150-56-57X	6"	11.00"	6.00"	7.75"	9.50"	14.00"	0.88"	0.75"	5.50"	8	86
41-200-56-57X	8"	13.50"	8.00"	9.00"	11.75"	19.50"	0.88"	0.80"	6.75"	8	165
41-250-56-57X	10"	16.00"	10.00"	13.50"	14.25"	24.50"	1.00"	1.20"	8.01"	12	450
41-300-56-57X	12"	19.00"	12.00"	15.37"	17.00"	27.50"	1.00"	1.26"	9.50"	12	570

56 = Lever & Weight Right Side

57 = Lever & Weight Left Side

