

AMERICAN AVK RESILIENT SEATED DUCTILE IRON GATE VALVE

Tested to AWWA C509 / C515 (NRS) for Indicator Post

Mechanical Joint Ends - Valve Sizes 4" - 16"

45/00X
MJxMJ PIV

Use:

For water and neutral liquids to maximum 160°F.

Tests:

Hydraulic test to AWWA C509:

Shell Test: 500 PSI 4"-12", 400 PSI 14"-16"

Seat Test: 250 PSI 4"-12", 200 PSI 14"-16"

Operating Torque Test

Optional Materials:

Stem	4"-12" only Stainless steel AISI 430F Stainless steel AISI 304 Stainless steel AISI 316
Bonnet Bolts	4"-12" only Stainless steel AISI 304, Stainless steel AISI 316, Zinc Plated steel sealed with hot melt
Gland Bolts	4"-12" only Stainless steel AISI 316, Zinc Plated steel

Standard Materials:

Body, Bonnet, Post Indicator Plate, Wrench Nut	Ductile iron ASTM A536 (Wrench Nut-painted black for open left, red for open right)
Coating	Electrostatically applied fusion- bonded epoxy-resin Meets or exceeds AWWA C550
Stem	4"-12" Standard: Low Zinc Bronze ASTM B763 14"-16" Standard: Aluminum Bronze ASTM B150
Anti Friction Washers	Polyamide
Wedge	Ductile iron ASTM A536 encapsulated with EPDM-rubber compound
Wedge Nut, Thrust Collar	Bronze
Bonnet Bolts	4" - 8" Stainless Steel - 304 sealed with hot melt 10"-16" High strength bolts sealed with hot melt
Gland Bolts	Stainless Steel - 304 Hexagon bolt
Bonnet Gasket, Wiper Ring, O-Ring Stem Seals, O-Ring Gland Seal	ASTM D2000 Buna "N" nitrile rubber

Approvals:



*UL/ULC Listed
*FM Approved
NSF-61 (audited by UL)

* Approved at 250 PSI working pressure, 4"-12"
* Approved at 200 PSI working pressure, 14"-16"

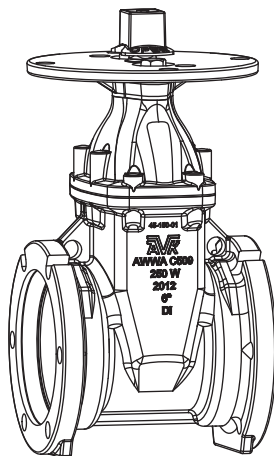

American AVK Company
an ISO 9001 registered company

DS S4500X MJMJ PIV
Subject to change without notice. (rev. 09/11)

AMERICAN AVK RESILIENT SEATED DUCTILE IRON GATE VALVE
Tested to AWWA C509 / C515 (NRS) for Indicator Post
Mechanical Joint Ends - Valve Sizes 4" - 16"

45/00X
MJxMJ PIV

Component List:

- | | | |
|---------------------------|------------------------------|-----------------------------|
| 217. Bonnet | 226. Wiper Ring | 232. Lower Stem Seal O-Ring |
| 218. Bonnet Gasket | 227. Gland Flange Bolt | 235. Anti-Friction Washer |
| 219. Body | 229. Gland O-Ring | 236. Low Zinc NRS Stem |
| 224. Post Indicator Plate | 230. Upper Stem Seal O-Rings | 237. Wedge |
| 225. Wrench Nut | 231. Stem Seal Bushing | |

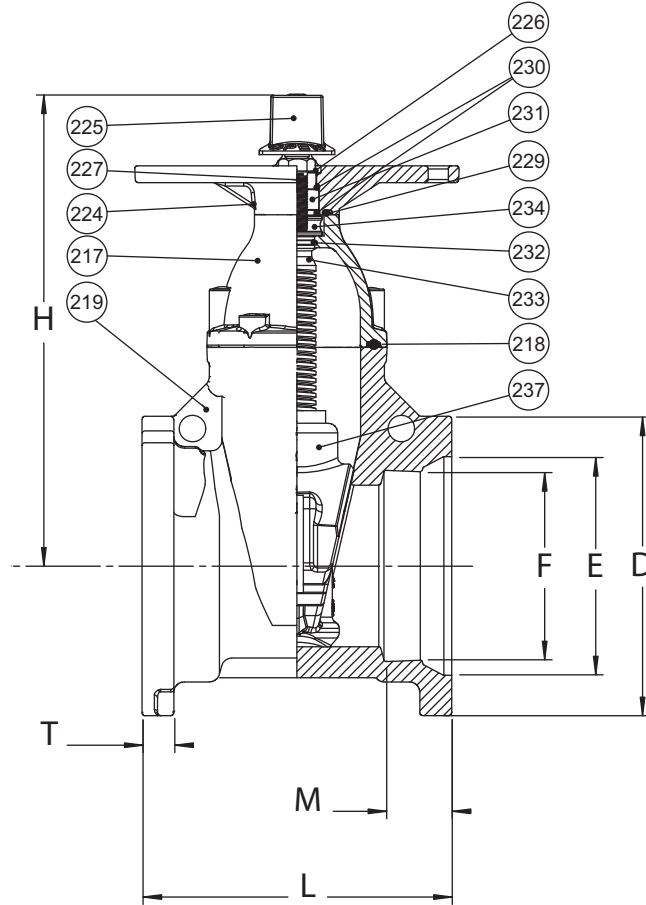

Ref No.	Size	D	E	F	H	L	M	T	Turns to Open	Weight (lbs.)
45-100-00X	4"	9.12"	6.00"	4.90"	13.50"	10.00"	2.50"	1.00"	14	82
45-150-00X	6"	11.12"	8.12"	7.00"	17.50"	11.50"	2.50"	1.18"	21	123
45-200-00X	8"	13.37"	10.27"	9.15"	21.50"	11.50"	2.50"	1.24"	26	175
45-250-00X	10"	15.69"	12.34"	11.20"	24.75"	13.00"	2.50"	1.14"	32	260
45-300-00X	12"	17.88"	14.44"	13.30"	27.63"	14.00"	2.50"	1.22"	38	357
45-350-00X	14"	20.31"	16.61"	15.50"	35.75"	17.95"	3.50"	1.32"	51	814
45-400-00X	16"	22.56"	18.64"	16.12"	34.75"	18.00"	3.50"	1.34"	51	820

