

AMERICAN AVK RESILIENT SEATED DUCTILE IRON GATE VALVE
250 PSI, Tested to AWWA C509 / C515 (OS&Y) CWP Tested to 350 PSI
Flanged x Flanged Ends to ANSI B16.1 Class 250 - Valve Sizes 4" - 12"
Laylength to ASME B16.10

45/46X
FLxFL

Use:

For water and neutral liquids to maximum 160°F.

Tests:

Hydraulic test to AWWA C509:

Shell Test: 500 PSI

Seat Test: 250 PSI

Hydraulic test CWP (Cold Working Pressure):

Shell Test: 525 PSI

Seat Test: 350 PSI

Operating Torque Test

Optional Materials:

| | |
|--------------------------|------------------|
| Bonnet Bolts, Stud Bolts | Stainless Steel, |
| Washers, Nuts | Grade 304 |

Standard Materials:

| | |
|--|---|
| Body, Bonnet, Yoke, Gland Follower | Ductile iron ASTM A536 |
| Handwheel | Cast iron ASTM A126 class B |
| Coating | Electrostatically applied fusion-bonded epoxy-resin Meets or exceeds AWWA C550 |
| Stem, Anti-Friction Washer, Wedge Nut 2-piece Stem Nut | Bronze |
| Wedge | Ductile iron ASTM A536 encapsulated with EPDM - rubber compound. |
| Bonnet Bolts | 4"-8": Zinc Plated Steel ASTM 164 10"-12": Grade 8 Steel |
| Stud Bolts, Washers, Nuts | Zinc Plated Steel |
| Bonnet Gasket, O-rings | NBR |
| Gland, Gland Bushing | Akulon |

Approvals:



- *UL/ULC Listed,
- *FM Approved
- * Approved at 250 PSI working pressure

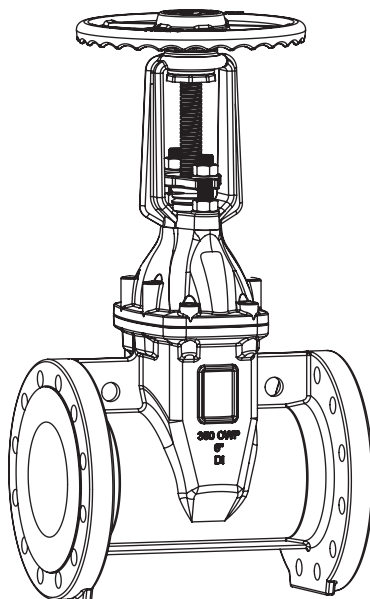

AMERICAN AVK RESILIENT SEATED DUCTILE IRON GATE VALVE
250 PSI, Tested to AWWA C509 / C515 (OS&Y) CWP Tested to 350 PSI
Flanged x Flanged Ends to ANSI B16.1 Class 250 - Valve Sizes 4" - 12"
Laylength to ASME B16.10

45/46X
FLxFL

Component List:

- | | | |
|---------------------------------|---------------------------|-------------------------------|
| 201. Upper Stem Nut | 208. Gland Follower | 215. OS&Y Stem Assembly |
| 202. OS&Y Handwheel | 209. Gland | 216. Bonnet Bolts (Not Shown) |
| 203. Anti-Friction Washer | 210. Stud Bolt | 217. Bonnet |
| 204. Yoke | 211. Stem Seal O-rings | 218. Bonnet Gasket |
| 205. Lower Stem Nut | 212. Inner Bushing O-ring | 219. Body |
| 206. Gland Follower/Yoke Nut | 213. OS&Y Bushing | |
| 207. Gland Follower/Yoke Washer | 214. Outer Bushing O-ring | |

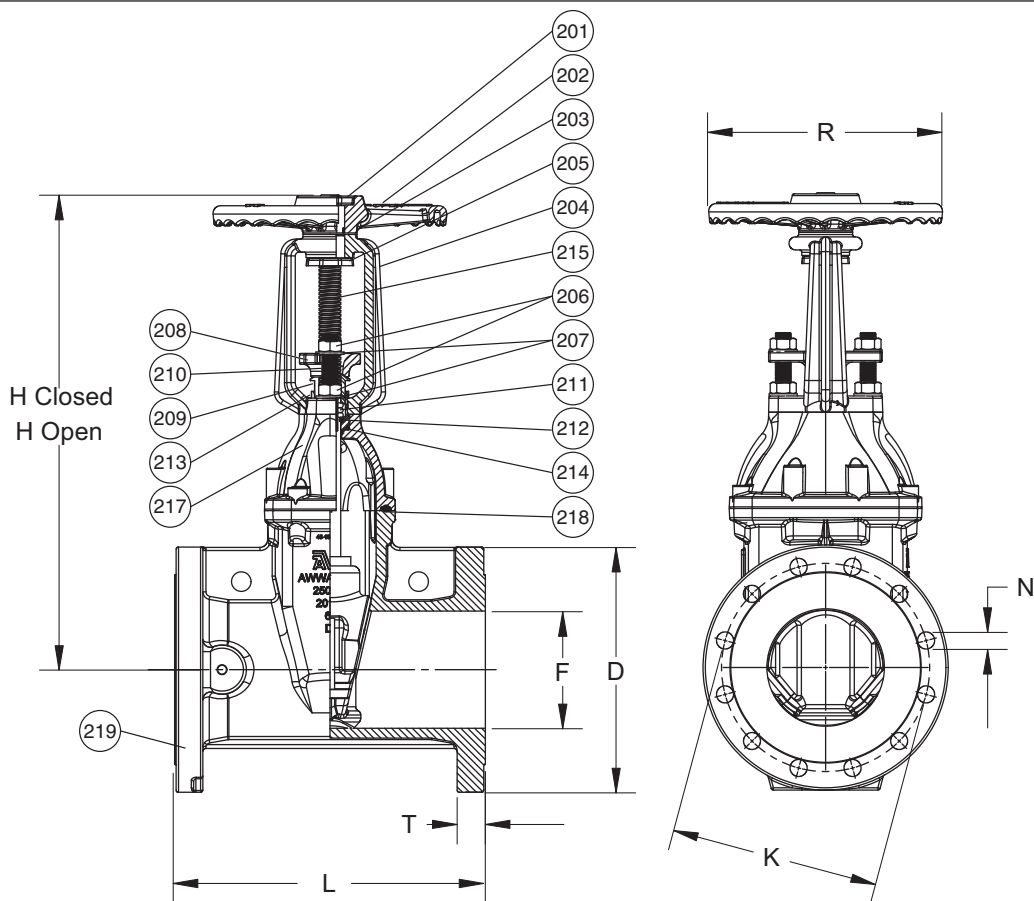

| Ref. nos. | Size | D | F | H open | H closed | K | L | N | R | T | Flange holes | Turns to open | Wt. Lbs. |
|------------|------|--------|--------|-----------|-------------|--------|--------|-------|--------|-------|-----------------|------------------|-------------|
| 45-100-46X | 4" | 10.00" | 4.00" | 22.63" | 18.63" | 7.88" | 12.00" | 0.88" | 10.00" | 1.25" | 8 | 21 | 113 |
| 45-150-46X | 6" | 12.50" | 6.00" | 31.00" | 25.00" | 10.62" | 15.88" | 0.88" | 12.00" | 1.44" | 12 | 26 | 202 |
| 45-200-46X | 8" | 15.00" | 8.00" | 39.00" | 31.00" | 13.00" | 16.50" | 1.00" | 14.00" | 1.62" | 12 | 35 | 301 |
| 45-250-46X | 10" | 17.50" | 10.00" | 46.80" | 36.80" | 15.25" | 18.00" | 1.12" | 17.00" | 1.88" | 16 | 37 | 400 |
| 45-300-46X | 12" | 20.50" | 12.00" | 53.50" | 41.50" | 17.75" | 19.76" | 1.25" | 17.00" | 2.00" | 16 | 44 | 563 |

