

AMERICAN AVK RESILIENT SEATED DUCTILE IRON GATE VALVE
Tested to AWWA C509 / C515 (NRS) for Indicator Post
Push-on Joint End x Push-on Joint End (TYTON) - Valve sizes 4" - 12" and 16"

45/C0X
POxPO PIV

Use:

For water and neutral liquids to maximum 160°F.

Tests:

Hydraulic test to AWWA C509:

Shell Test: 500 PSI 4"-12", 400 PSI 16"

Seat Test: 250 PSI 4"-12", 200 PSI 16"

Operating Torque Test

Optional Materials:

| | |
|--------------|---|
| Stem | 4"-12" only Stainless steel AISI 430F Stainless steel AISI 304 Stainless steel AISI 316 |
| Bonnet Bolts | 4"-12" only Stainless steel AISI 304, Stainless steel AISI 316, Zinc Plated steel sealed with hot melt |
| Gland Bolts | 4"-12" only Stainless steel AISI 316, Zinc Plated steel |

Standard Materials:

| | |
|--|--|
| Body, Bonnet, Post Indicator Plate, Wrench Nut | Ductile iron ASTM A536 (Wrench Nut-painted black for open left, red for open right) |
| Coating | Electrostatically applied fusion- bonded epoxy-resin Meets or exceeds AWWA C550 |
| Stem | 4"-12" Standard: Low Zinc Bronze ASTM B763 16" Standard: Aluminum Bronze ASTM B150 |
| Anti Friction Washers | Polyamide |
| Wedge | Ductile iron ASTM A536 encapsulated with EPDM-rubber compound |
| Wedge Nut, Thrust Collar | Bronze |
| Bonnet Bolts | 4" - 8" Stainless Steel - 304 sealed with hot melt 10"-16" High strength bolts sealed with hot melt |
| Gland Bolts | Stainless Steel - 304 Hexagon bolt |
| Bonnet Gasket, Wiper Ring, O-Ring Stem Seals, O-Ring Gland Seal | ASTM D2000 Buna "N" nitrile rubber |

Approvals:



*UL/ULC Listed
 *FM Approved
 NSF-61 (audited by UL)

* Approved at 250 PSI working pressure, 4"-12"
 * Approved at 200 PSI working pressure, 16"

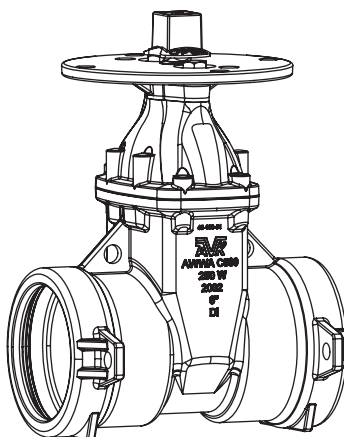

American AVK Company
 an ISO 9001 registered company

DS S45C0X POPO PIV
 Subject to change without notice. (rev. 09/11)

AMERICAN AVK RESILIENT SEATED DUCTILE IRON GATE VALVE
Tested to AWWA C509 / C515 (NRS) for Indicator Post
Push-on Joint End x Push-on Joint End (TYTON) - Valve sizes 4" - 12" and 16"

45/C0X
POxPO PIV

Component List:

- | | | |
|---------------------------|------------------------------|-----------------------------|
| 217. Bonnet | 226. Wiper Ring | 232. Lower Stem Seal O-Ring |
| 218. Bonnet Gasket | 227. Gland Flange Bolt | 235. Anti-Friction Washer |
| 219. Body | 229. Gland O-Ring | 236. Low Zinc NRS Stem |
| 224. Post Indicator Plate | 230. Upper Stem Seal O-Rings | 237. Wedge |
| 225. Wrench Nut | 231. Stem Seal Bushing | |

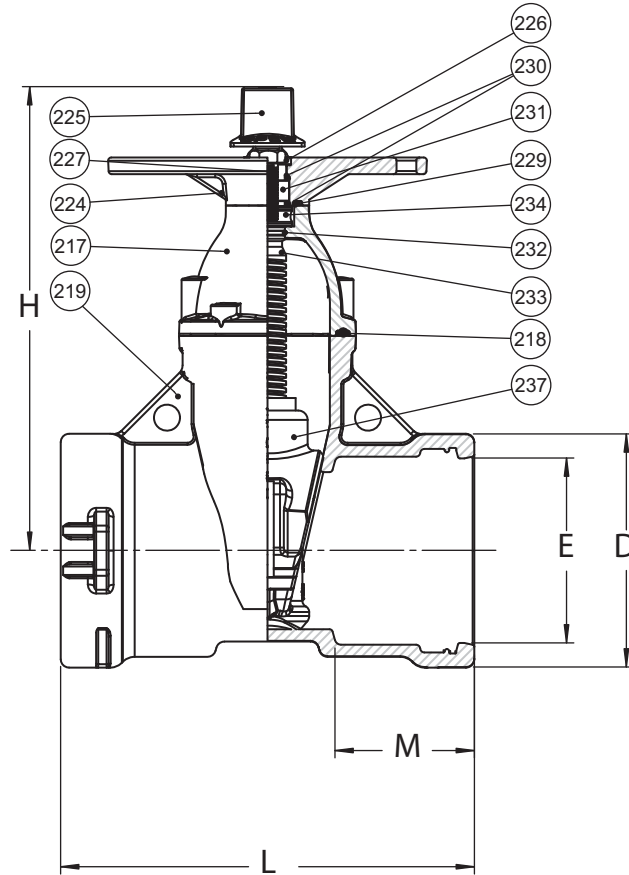

| Ref No. | Size | D | E | H | L | M | Turns to Open | Weight (lbs.) |
|------------|------|--------|--------|--------|--------|-------|---------------|---------------|
| 45-100-C0X | 4" | 6.66" | 4.93" | 13.50" | 11.99" | 4.12" | 14 | 77 |
| 45-150-C0X | 6" | 8.84" | 7.03" | 17.50" | 15.63" | 5.22" | 21 | 117 |
| 45-200-C0X | 8" | 11.23" | 9.18" | 21.50" | 17.17" | 5.63" | 26 | 177 |
| 45-250-C0X | 10" | 13.50" | 11.22" | 24.75" | 17.64" | 5.63" | 32 | 247 |
| 45-300-C0X | 12" | 15.74" | 13.32" | 27.75" | 19.21" | 5.63" | 38 | 411 |
| 45-400-C0X | 16" | 20.62" | 17.50" | 34.75" | 22.72" | 6.00" | 51 | 1002 |

