

AMERICAN AVK RESILIENT SEATED DUCTILE IRON GATE VALVE
250 PSI, Tested to AWWA C509 (NRS)
Push-on ends for IPS PVC Pipe-2"

45/C7X
PO

Component List:

- | | |
|--------------------|--------------------|
| 216. Bonnet Bolt | 237. Wedge |
| 217. Bonnet | 238. Outer O-rings |
| 218. Bonnet Gasket | 239. Inner O-rings |
| 219. Body | 240. Slide Bearing |
| 225. Wrench Nut | 241. Stem Collar |
| 226. Wiper Ring | 242. Stem Seal |
| 233. Stem | 243. Gasket |

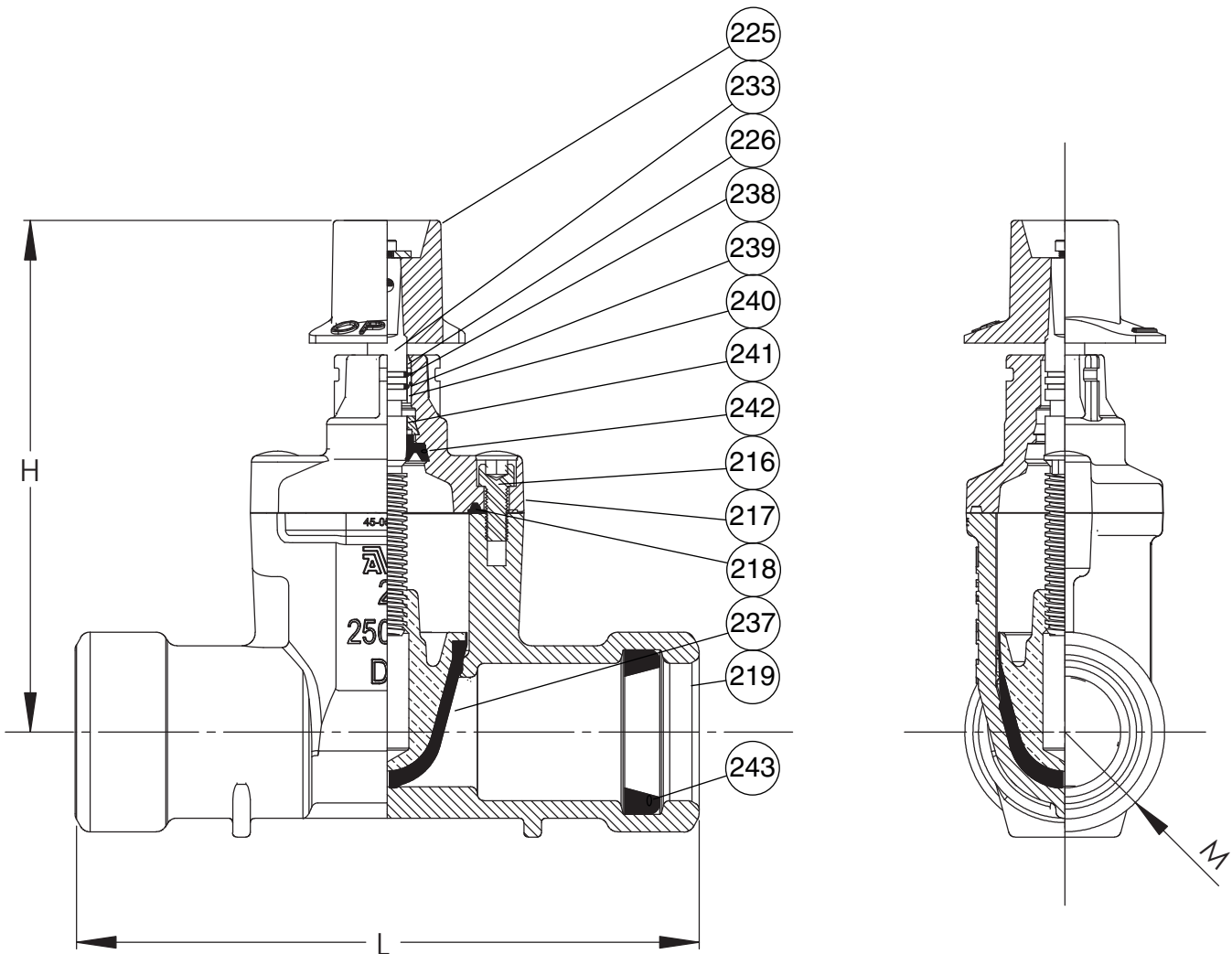

Ref. nos.	Size	H	L	W	Turns to Open	Wt. Lbs.
45-050-C7X	2"	10.50"	11.22"	3.59"	13	18

