

AMERICAN AVK HIGH PRESSURE, 250 PSI, POST, DRY BARREL HYDRANT

**67XX
POST**

Complies with AWWA C502 (latest) - (where applicable) - Working Pressure - 250 PSI
 Inlet Bases: NPT, Flanged in accordance with ANSI B16.1 Class 125,
 Mechanical Joint in accordance with ANSI/AWWA C111/A21.11

Use:
 For water and neutral liquids to maximum 160°F.

Tests:
 Seat Test: 375 PSI

Components: Nozzle Section, Barrels, Breakable Flange, Base		Standard: Ductile Iron ASTM A536	
Caps, Weathershield		Cast Iron ASTM A126 Class "B"	
Nozzle, Valve Seat Ring, Main Valve Flange Operating Nut, Thrust Nut		Bronze	
Main Valve		Ductile iron core, fully encapsulated with EPDM rubber.	
Stem Rod Couplings, Upper Stem Rod, Nozzle Retaining Screw, Thrust Nut Screw, Coupler Pins, Main Valve Retaining Pin, Spring Pins		Stainless Steel	
Coating - Above ground		Acrylic Polyurethane paint	
Coating - Below ground		Fusion bonded epoxy. Epoxy meets or exceeds AWWA C550 (latest)	
Chain Set, Hardware		Zinc Plated Steel	
Cap Gasket, O-rings		NBR	
Anti-Friction Washer		Brass	
Base Elbow / Inlet Configuration	<input type="checkbox"/> 2" MJ <input type="checkbox"/> 3" MJ <input type="checkbox"/> 4" MJ	<input type="checkbox"/> 2.5" Flanged <input type="checkbox"/> 3" Flanged	<input type="checkbox"/> 2" NPT <input type="checkbox"/> 2.5" NPT <input type="checkbox"/> 3" NPT
	Optional Materials:		
Hardware	<input type="checkbox"/> Zinc Plated (STD)	<input type="checkbox"/> 304 Stainless	<input type="checkbox"/> 316 Stainless
Lower Stem Rod	<input type="checkbox"/> 304 Stainless	<input type="checkbox"/> Steel (STD)	
Opening Direction	<input type="checkbox"/> Open Left	<input type="checkbox"/> Open Right	

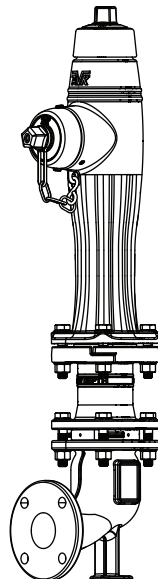

Series 67XX
1 Hose Outlet



American AVK Company
 an ISO 9001-2000 registered company

DS S67XX POST
 Subject to change without notice. (rev. 01/08)

AMERICAN AVK HIGH PRESSURE, 250 PSI, POST, DRY BARREL HYDRANT

**67XX
POST**

Complies with AWWA C502 (latest) - (where applicable) - Working Pressure - 250 PSI

Inlet Bases: NPT, Flanged in accordance with ANSI B16.1 Class 125,

Mechanical Joint in accordance with ANSI/AWWA C111/A21.11

Component List:

1. Weathershield Bolt
2. Weathershield
7. Valve Seat O-ring
19. Hose Nozzle Cap
20. Hose Nozzle
21. Hose Nozzle Cap Gasket
22. Hose Nozzle O-ring
23. Set Screw - (Nozzle)
24. Chain Assembly
31. Nozzle Section Washer
34. Nozzle Section Nut
38. Spring Pin
52. Thrust Nut O-ring
59. Set Screw - (Thrust Nut)
73. Flange O-ring
75. Zerk Fitting
76. Thrust Nut
500. Operating Nut
501. Anti Friction Washer
502. Stem Seal O-ring
503. Upper Stem Rod
504. Nozzle Section
505. Two Piece Breakable Flange
506. Nozzle Section Bolt
507. Coupler Pin
508. Breakable Coupling
509. Lower Barrel
510. Lower Stem Rod
514. Main Valve Flange
515. Seat Ring
516. Main Valve Retainer Pin
517. Cotter Pin
518. Main Valve
519. Base

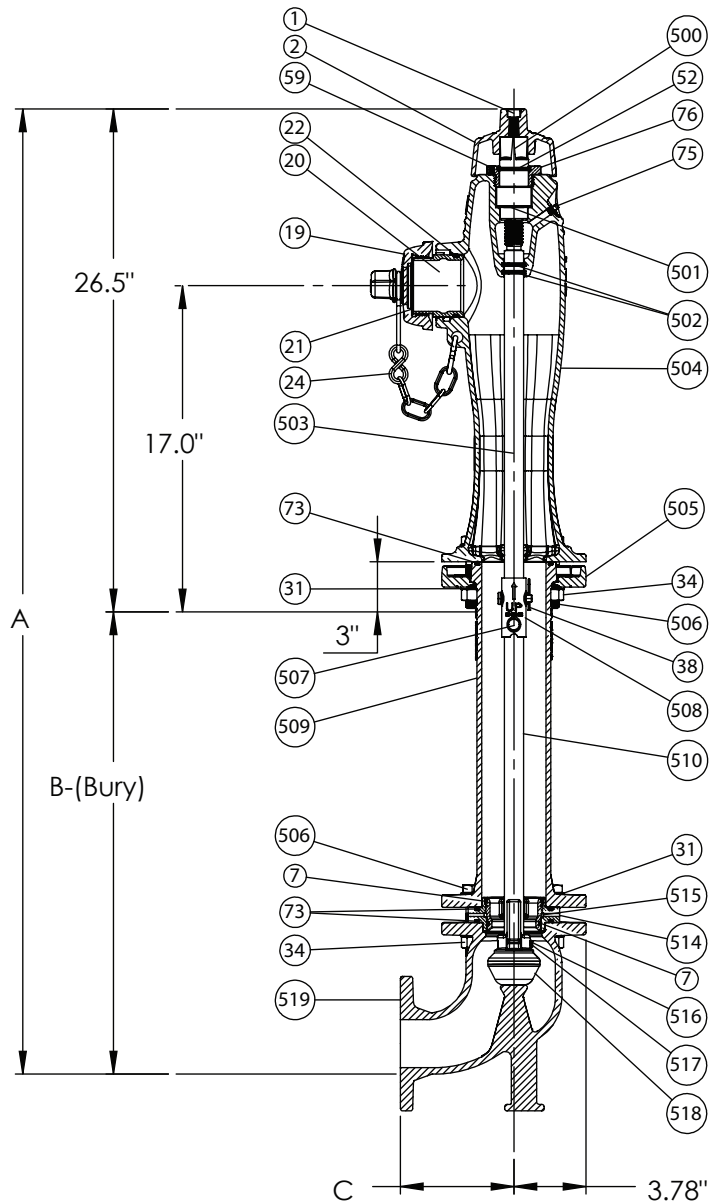

Notes:

1. F23 - Set Screw for Hose Nozzle, not shown.

Ref No.	A*	B*	C		
			Flanged	MJ	NPT
67-XX - 2"	38.50" - 86.50"	12.00" - 60.00"	N/A	6.00"	4.50"
67-XX - 2.5"	38.50" - 86.50"	12.00" - 60.00"	6.00"	N/A	5.12"
67-XX - 3"	38.50" - 86.50"	12.00" - 60.00"	6.00"	7.00"	5.12"
67-XX - 4"	38.50" - 86.50"	12.00" - 60.00"	N/A	7.00"	N/A

* Dimension "A" - 92.50" - 140.50" if using extension barrels, bury depth in 6" increments.

* Dimension "B" - 66.00" - 114.00" if using extension barrels, bury depth in 6" increments.

