

**AMERICAN AVK RESILIENT SEATED DUCTILE IRON GATE VALVE**  
**250 PSI, Tested to AWWA C509 (OS&Y)**  
**- DI Grooved End according to AWWA C606 x Flanged - Valve Sizes 3" - 8"**

**45/86X**  
**DI GRxFL**

**Use:**

For water and neutral liquids to maximum 160°F.

**Tests:**

Hydraulic test to AWWA C509:

Shell Test: 500 PSI

Seat Test: 250 PSI

Operating Torque Test

**Optional Materials:**

Bonnet Bolts, Stud Bolts	Stainless Steel,
Washers, Nuts	Grade 304

**Standard Materials:**

Body, Bonnet, Yoke, Gland Follower	Ductile iron ASTM A536
Handwheel	Cast iron ASTM A126 class B
Coating	Electrostatically applied fusion-bonded epoxy-resin Meets or exceeds AWWA C550
Stem, Anti-Friction Washer, Wedge Nut 2-piece Stem Nut	Bronze
Wedge	Ductile iron ASTM A536 encapsulated with EPDM - rubber compound.
Bonnet Bolts	4"-8": ASTM A 164 Zinc Plated Steel 10"-12": Grade 8 Steel
Stud Bolts, Washers, Nuts	Zinc Plated Steel
Bonnet Gasket, O-rings	NBR
Gland, Gland Bushing	Akulon

**Approvals:**



\*UL/ULC Listed,

\*FM Approved

\* Approved at 250 PSI working pressure

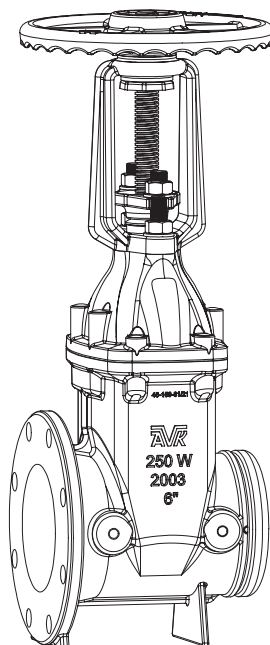

American AVK Company  
an ISO 9001-2000 registered company

DS S4586X DI GRFL  
Subject to change without notice. (rev. 09/07)

**AMERICAN AVK RESILIENT SEATED DUCTILE IRON GATE VALVE**  
**250 PSI, Tested to AWWA C509 (OS&Y)**  
**- DI Grooved End according to AWWA C606 x Flanged - Valve Sizes 3" - 8"**

**45/86X**  
**DI GRxFL**

**Component List:**

- |                              |                                 |                           |
|------------------------------|---------------------------------|---------------------------|
| 201. Upper Stem Nut          | 207. Gland Follower/Yoke Washer | 214. Outer Bushing O-Ring |
| 202. OS&Y Handwheel          | 208. Gland Follower             | 215. OS&Y Stem Assembly   |
| 203. Anti-Friction Washer    | 209. Gland                      | 217. Bonnet               |
| 204. Yoke                    | 210. Stud Bolt                  | 218. Bonnet Gasket        |
| 205. Lower Stem Nut          | 211. Stem Seal O-Ring           | 219. Body                 |
| 206. Gland Follower/Yoke Nut |                                 |                           |

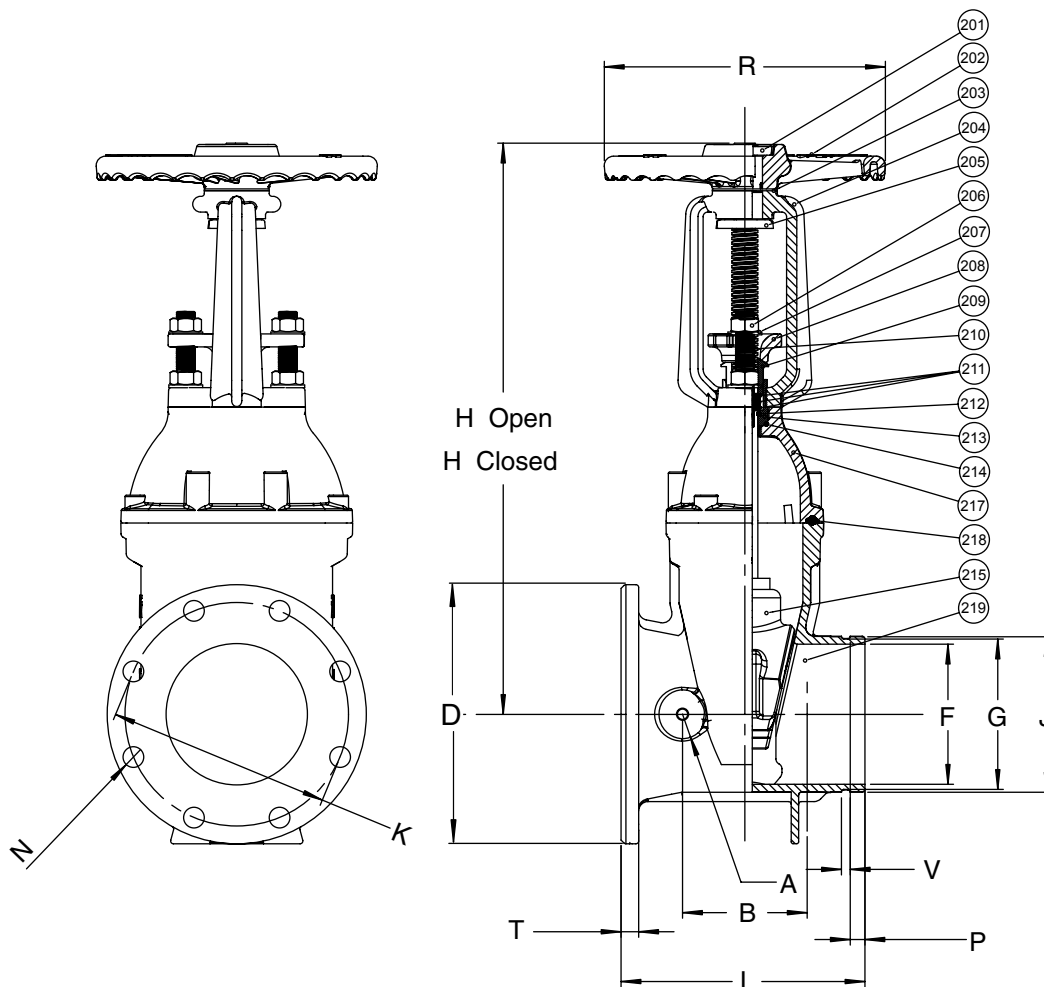

Ref No.	Size	A	B	D	F	G	H Open	H Closed	J	K	L	N	P	R	T	V	Turns to Open	Weight Lbs.
45-080-86X	3"	1.57"	3.74"	7.52"	3.00"	3.71"	17.00"	14.00"	3.93"	6.00"	8.00"	0.75"	0.75"	7.08"	0.75"	0.38"	20	48
45-100-86X	4"	1.65"	4.12"	9.00"	4.00"	4.56"	21.00"	17.00"	4.80"	7.50"	9.00"	0.75"	0.75"	10.00"	0.75"	0.38"	21	64
45-150-86X	6"	1.97"	5.29"	11.00"	6.00"	6.65"	29.50"	23.50"	6.90"	9.50"	10.50"	0.88"	0.75"	12.00"	0.75"	0.38"	26	111
45-200-86X	8"	1.97"	8.00"	13.50"	8.00"	8.78"	37.50"	29.50"	9.05"	11.75"	11.50"	0.88"	0.87"	14.00"	0.79"	0.50"	35	165

